

# OPERATOR'S MANUAL FOR DOUBLE ACTING PISTON HAND PUMP

OPERATION AND SERVICE GUIDE  
PO-15501  
JUNE 2016

## SAFETY WARNING

Verify the chemical compatibility of the materials of your pump with the liquid you want to pump. If you are uncertain regarding chemical compatibility, contact your dealer for applications assistance and request a copy of our Corrosion Resistance Charts. Do not use a pump that is not chemically compatible with the liquid you intend to pump or serious bodily injury, death, fire, explosion or environmental damage could result.

### Table of Contents

**PLEASE READ SECTIONS I, II, III, IV AND VIII BEFORE OPERATING PUMP**

	Page #	Page #	
I. UPON RECEIPT OF THE PUMP .....	1	V. PUMP PARTS LIST .....	3,4
II. DESCRIPTION .....	1	VI. TROUBLE SHOOTING GUIDE .....	5
III. SAFETY PRECAUTIONS .....	2	VII. MAINTENANCE .....	5
IV. PUMP OPERATING INSTRUCTIONS .....	2	VIII. SAFETY INFORMATION .....	6

## I. UPON RECEIPT OF PUMP

- A. Inspect each pump for shipping damage immediately upon receipt before signing for merchandise. If any visible damage exists, note damage on shipping bill of lading or receiving documents before signing. Claims for damage must be made with the carrier. Also, notify your dealer or distributor immediately of any damage to the shipment.
- B. Depending on model number and options ordered the following parts are shipped loose in the carton and should be checked before destroying the carton and packaging material. See the drawing in section V to help identify these parts.

1. - 1 bung adaptor #32
2. - 1 clamp #31
3. - 1 hose #17, complete with: 1 hose adapter #21, 1 nozzle #15, 2 hose clamps #16
4. - 1 suction tube # 36
5. - 1 extension tube # 34
6. - 1 coupling # 35
7. - 1 discharge spout

## II. DESCRIPTION

A. If you have not checked the chemical compatibility of your pump with the liquid *do it now before using the pump!* The pump is equipped in one of several ways. Compare your model number with the model number chart immediately preceding the parts list in section V. This will tell you what materials make up your pump. Consult the factory for *any* chemical applications. A chemical resistance chart is packed with the pump.

B. The pump handle can be easily positioned either up for normal use, or down, allowing the pump to be elevated. This would be convenient for example when pumping from a truck mounted drum or barrel. See section IV, step F.

C. A siphon breaker is built into the pump discharge. This prevents siphoning from the drum if the hose drops from its hanger. It also allows the hose to drain completely after pumping.

D. The barrel is vented by 4 relief channels molded into the bung adaptor. This prevents drawing a vacuum in the barrel.

E. The suction tube (#36) and extension tube (#34) supplied are cut to fit a standard 55 gallon drum. The suction tube has a bevel cut at one end and is threaded at the other end.

The extension tubes are threaded at both ends. Extra extension tubes (#34) and couplings (#35) may easily be used for deeper vessels such as tanks. Maximum suction lift is 15 feet.

1. A 55 gallon drum on end requires 1 extension tube, 1 coupling and 1 suction tube threaded together.
2. To use the side bung hole on a 55 gallon drum thread together one extension tube one coupling, and a 5" length of suction tube. The plastic tube can easily be cut with a hacksaw. Make the cut at an angle. **DO NOT CUT THE THREADED END.**
3. For 275 gallon tanks, thread together two extension tubes and one suction tube.

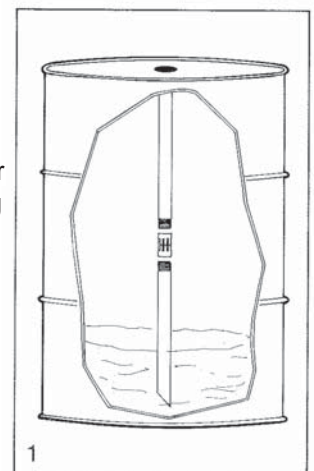

# III. SAFETY PRECAUTIONS

- A. This manual contains important information for the safe and proper operation of this pump. Read it THOROUGHLY before operating or installing the pump.
- B. USE ONLY ORIGINAL FACTORY REPLACEMENT PARTS.
- C. When pumping flammable liquids, ensure adequate ventilation to prevent explosive build up of fumes. Pumping should always be done in a "NO SMOKING" area. Approved fire extinguishers, in good condition, should be available for fire suppression.
- D. Containers holding flammable liquids should be grounded, and portable containers bonded, to prevent explosion hazards from static electricity charges. See page 6.
- E. Operators should be properly instructed on operating procedures and safety precautions.
- F. Do not use torches or apply fire or flame to this pump for any reason.
- G. When pumping corrosives personal protection such as rubber

- gloves, aprons, eye shields and adequate ventilation. Consult chemical manufacturer for additional cautions.
- H. **Do not overtighten nonmetallic threaded fittings. One full turn past hand tight is usually enough to prevent leakage.** One roll of teflon tape is provided and should be used on all threaded joints.
- I. Inspect the siphon breaker regularly to ensure proper operation. To test siphon breaker, lay hose on ground with nozzle in a suitable container to hold the liquid. Operate the handle until liquid flows from the nozzle. Stop pumping: the hose should drain and the flow stop. If flow continues without moving the handle, place the nozzle in its hanger to stop the flow. Then inspect the siphon breaker vent for blockage or freezing. Flush the vent with water, or if pumping petroleum products, use clean product.

## TO PREVENT SPILLING LIQUID WHEN REMOVING PUMP FROM BARREL, OBSERVE THE FOLLOWING PRECAUTIONS:

1. Straighten discharge hose and hold it below the pump discharge. Allow hose to drain into a container.
2. Loosen stainless steel clamp item #31.
3. Pull pump from bung adaptor and allow suction tube to drain back to the barrel. Lay pump flat with handle up. Place container under nozzle. Operate handle until liquid is clear from pump housing.
4. Allow discharge hose to drain. Place the hose nozzle in its hanger. If pump will not be installed in a new barrel, any caustic or corrosive chemicals should be flushed with fresh water internally and externally to prevent personal injury during handling. ANY PUMP USED TO TRANSFER FLAMMABLE LIQUIDS MUST BE STORED IN A WELL VENTILATED AREA AFTER USE.

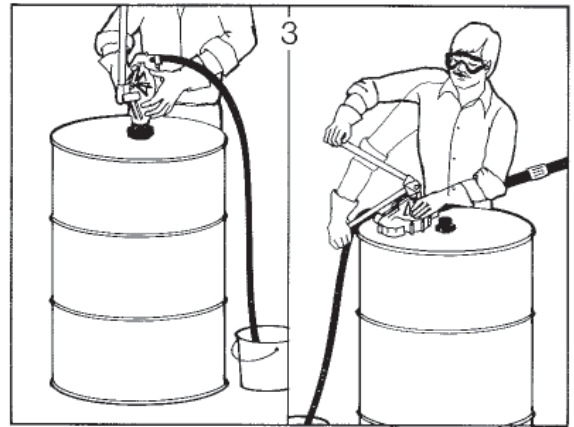

# IV. PUMP OPERATING INSTRUCTIONS

## FOR EASY INSTALLATION FOLLOW THESE STEPS IN THE ORDER SHOWN.

- A. Screw the bung adaptor into the drum or barrel. Be sure not to overtighten. (Refer to section III.H)
- B. Install supplied clamp loosely around bung adaptor.
- C. Thread appropriate length of suction tube and extension tube(s) into pump section. Use teflon tape provided. (Refer to section III.H)
- D. Install pump and tubing into bung adaptor by pushing straight down firmly. Housing will snap in place. Tighten the clamp (item #31). Screw hose and adaptor or discharge spout into pump body.

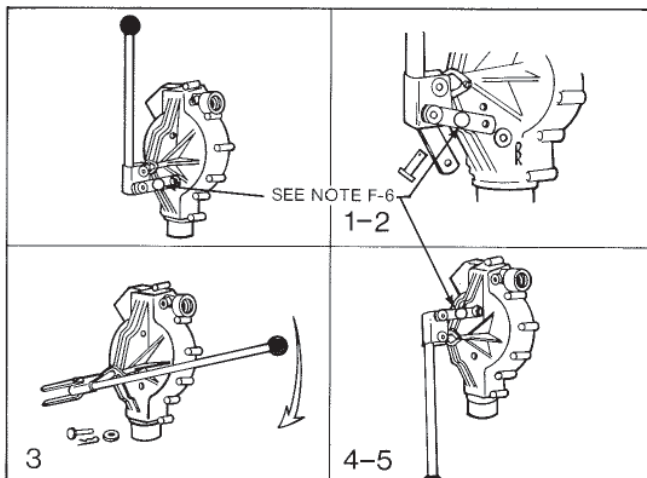
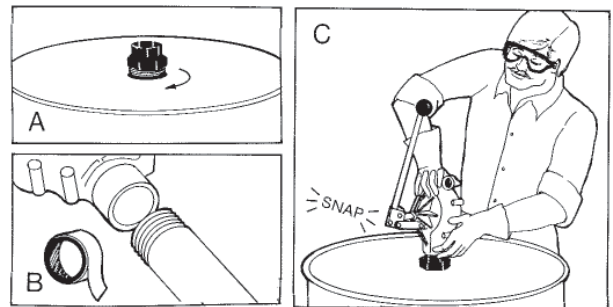

- E. Caution: When pumping from a lined drum, order part # 58-0069. This is a flexible suction tube and will prevent damage to the liner.
- F. The handle position can be changed with the following steps.
  1. Remove hairpin clip (6) from clevis pin (7).
  2. Remove clevis pin from housing to free links, (8).
  3. With links clear of housing, rotate handle 1/2 turn to new position.
  4. Install clevis pin through the links and the opposite hole in housing.
  5. Install hairpin clip through the hole in the clevis pin. Ensure the flat washer (4) is installed between the hairpin clip and the link.
  6. CAUTION: This hole is used for security lock only.
- G. Remove hose from hanger and place nozzle in container. Operate handle to prime the pump. 3-6 strokes are required under most conditions. After the pump is primed it will deliver about one gallon for every four full strokes (backward and forward).

## TWO POSITION PUMP HANDLE

# HAND DISPENSING PUMP SERIES "HP"

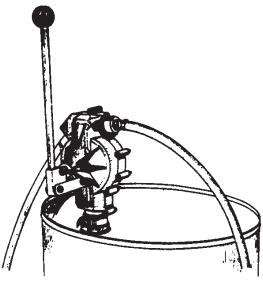

The model numbering system for the Hand Pump is made up of 7 digits, each of which tells something about how the pumps are built. The following chart explains each digit.

1st Digit Series	2nd Digit Housing Material	3rd Digit Elastomers	4th Digit Discharge Hose	5th Digit Suction Tube	6th Digit Discharge Spout	7th Digit Buttress Bung Adapter
H	P-Polyester	V-Gasket: Viton O-rings: Viton Vacuum Breaker: Viton	1-EPDM w/Polyester Elbow & Nozzle 2-Nitrile w/Polyester Elbow & Nozzle	A-Polyester Suction Tube	M-Polyester Discharge Spout	R-Polypropylene/Polyester Assy. for HP Pump
	R-Ryton	N-Gasket: Cork/Nitrile O-rings: Viton Vacuum Breaker: Viton	3-PVC (Black) w/ Polyester Elbow & Nozzle 4-Clear Reinforced PVC Hose w/Polyester Elbow & Nozzle	B-Halar Suction Tube w/ Fluoropolymer Coupling	N-Fluoropolymer Discharge Spout	S-Polypropylene/Fluoropolymer Assy. for HP Pump
		E-Gasket: EPDM O-rings: EPDM Vacuum Breaker: EPDM	5-Clear Reinforced PVC Hose w/Halar Elbow & Nozzle 6-EPDM w/Fluoropolymer Elbow & Nozzle 6-EPDM w/Fluoropolymer Elbow & Nozzle 7-Nitrile w/Fluoropolymer Elbow & Nozzle 8-PVC w/Fluoropolymer Elbow & Nozzle	C-UHMW-PE Suction Tube w/ Fluoropolymer Coupling		

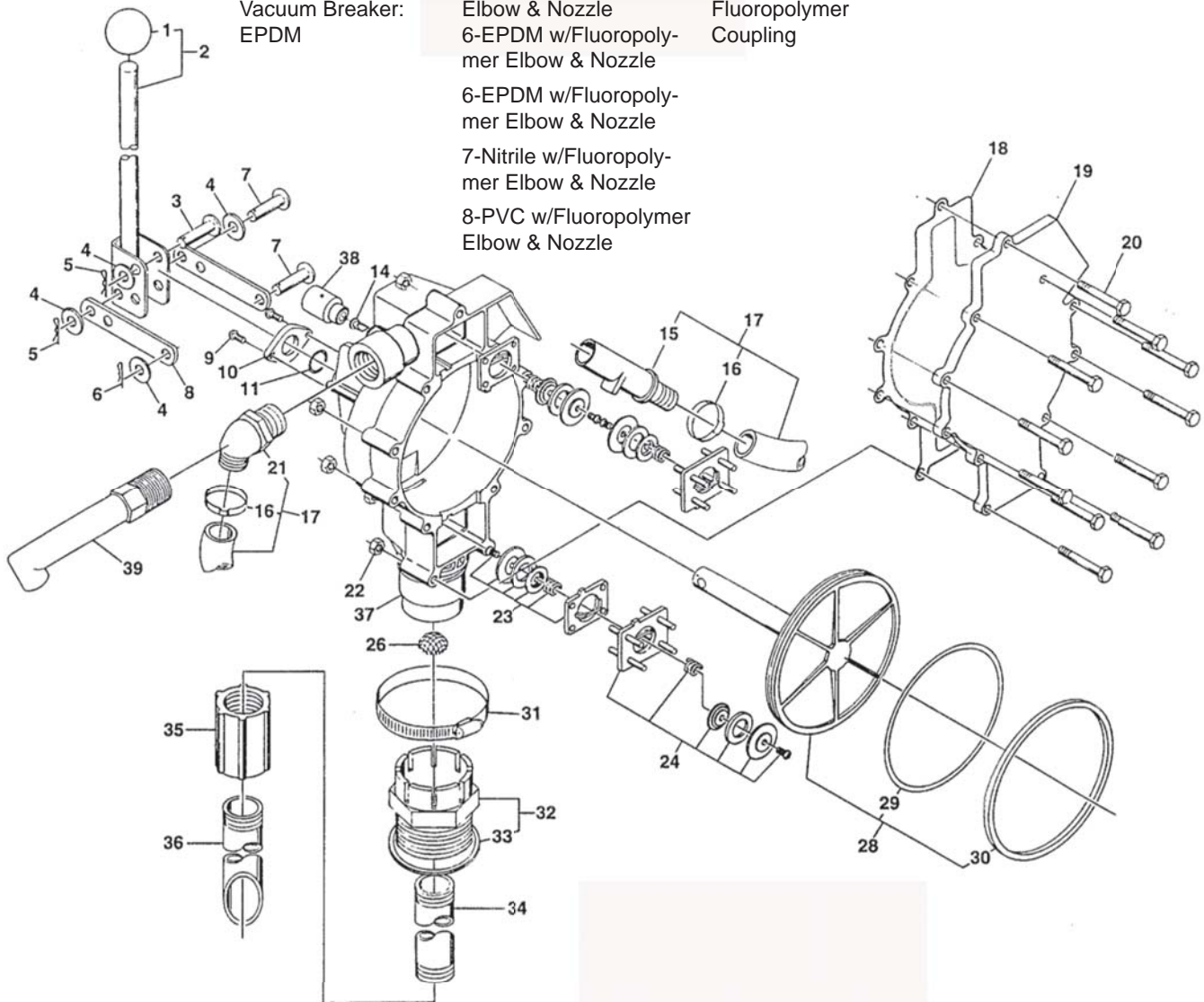



# VI. TROUBLE SHOOTING GUIDE

## A. pump will not prime

1. Clogged suction. Check that the suction tubes are clear and that the screen filter is not dirty or clogged. Use a pair of needle nose pliers or a stiff piece of wire to pull the suction screen from housing. Clean it, if necessary, and push it gently back into the housing or with a finger or blunt rod.

2. Air leakage. Check that the connection to housing, extension tube and suction tube are threaded tightly and sealed with teflon tape. (Section III.H)

3. Piston leakage. Verify that the teflon ring fits snugly in bore and is not cut or excessive worn.

4. Valve leakage. Inspect poppet valves for weak springs or clogging. If pump was recently disassembled VERIFY PROPER POSITION OF VALVE SEATS. Refer to section VII.B1.

5. Gasket leaks. Inspect for torn gasket (#18), poor fit or loose coverplate bolts (#20).

## B. Not Enough Flow

1. Check items A. 1-5 above. Check discharge hose for clogging or pinching. Verify that the nozzle is not clogged.

2. Check that piston is travelling its full stroke and the linkage has not bound or jammed.

# VII. MAINTENANCE

## USE ONLY ORIGINAL FACTORY REPLACEMENT PARTS.

### A. DISASSEMBLY.

1. Remove hose (#17) from housing. Unscrew suction and/or extension tubes (#34 & #36).

2. Remove hex nuts (#22) and screws (#20) from housing. Remove cover plate and gasket (#19 & #18), being careful not to damage the gasket.

3. Remove large and small valve assemblies (#24 & #23) and inspect for broken or weak springs, or damaged or clogged valves.

4. Remove hairpin clip (#5), washer (#4) and clevis pin (#3) which hold the handle (#2) to the piston rod. Remove hairpin clip (#6), flat washer (#4) and clevis pin (#7) from links (#8) at the pump housing (#37). Remove pin (#3) from piston rod and set handle aside. Slide piston assembly (#28) from the housing.

5. Inspect teflon ring (#30) in piston groove. It must extend about 1/32nd above the edge of the piston to seal properly. If the ring is worn flush with the piston edge it must be replaced. When removing the teflon ring be careful not to damage the piston if tools are being used. Always replace the O-ring (#29) when replacing the teflon ring. The rubber O-ring is compressed over time, reducing its ability to seal.

6. Inspect piston bore in housing (#37) for wear. Any gouging or scraping would indicate that the liquid being pumped contains abrasives. Replace the housing and teflon ring if the surfaces are gouged or worn.

7. Remove the two screws (#9) that hold the retaining plate (#10) to the housing. Remove plate to expose piston rod O-ring (#11). Replace O-ring if worn.

### B. REASSEMBLY.

1. Install the two small valve assemblies (#23) in the housing first, then the two large assemblies (#24). There is a small tab molded into the valve seats which fits a guide channel in the housing. This prevents installing the valve seats backwards. If the tabs are broken, please note the following.

a. The suction valve seats (lower two) should have their springs facing each other when installed.

b. The discharge valve seats (upper two) should have springs facing away from each other.

2. Install piston rod O-ring (#11). Install retainer plate (#10) with the groove facing AWAY from the pump housing. Ensure piston (#28) has O-ring (#29) and teflon ring (#30) installed. Teflon ring will stretch enough to install by hand (tools may damage the piston). Slide piston rod into housing. The teflon ring will catch on the edge of the housing while pushing the piston into the bore. To help seat the ring, turn piston slowly while pushing ring into the groove with fingers. DO NOT FORCE PISTON.

3. Inspect the cover plate gasket (#18) for damage.

4. Lay coverplate and gasket on housing and install screws (#20) and hex nuts (#22). Tighten firmly enough to compress gasket.

5. Install short clevis pin (#3) through the piston rod and handle securing with washer (#4) and hairpin clip (#5). Install clevis pin (#7), flat washer (#4) and links (#8) at the pump housing.

6. Install hose and suction extension tubes as required. Refer to section III.I and Section II.E.

## LIMITED ONE YEAR WARRANTY

Pacer Pumps warrants its products to be free from defects of material and workmanship for a period of one year (12 months) of service, if the one year of service falls within the 24 months from date of manufacture. The company warrants that all its products, at the time of shipment, will be free from defects in material and workmanship for normal use and service. This warranty will not apply or be extended to products subjected to misuse, neglect, accident, or improper installation, or to maintenance of products which have been altered or repaired by anyone except Pacer Pumps or its authorized representatives, the buyer, or person receiving such a product during the duration of the warranty, shall contact his Pacer Pumps dealer as soon as any defect occurs. Contact Pacer Pumps for the name and address of your nearest dealer.

Pacer Pumps' sole obligation under the foregoing warranty shall be limited to: (at its option) repair and replacement (and re-ship to the buyer with transportation charges collect to any place in the U.S.) of defective goods provided that if the company is unable to correct a defective component, part or product, the Buyer shall be entitled to elect a credit at the original buyer's purchase price. To return a DEFECTIVE PUMP, to return any parts for credit, or to obtain service information, contact the service department. After receiving permission to return defective merchandise, the buyer is authorized to return the product to Pacer Pumps, freight prepaid. If the company determines that the warranty has

not been breached, product will be repaired or replaced free of charge.

The company will not be responsible for any damage or losses, direct or indirect, arising from any cause whatsoever, nor for damage to equipment caused by outside influences including improper installation or modification, improper voltage supply, lightning, corrosive liquids, abrasive liquids, or careless handling; nor for labor, transportation or other damages incurred in the replacement or repair of replacement parts. In these cases repair will be subject to reconditioning charges in effect at the current time.

Purchased merchandise, either as a complete product for resale, or components used in conjunction with Pacer Pumps manufactured products, carries the warranty of the respective manufacturer of such product or components.

This warranty supersedes any warranty previously in effect.

41 Industrial Circle  
Lancaster, PA 17601-5927  
Email: sales@pacerpumps.com

717-925-8240  
800-233-3861

FAX: 717-656-0477

**PACER PUMPS**  
Division of ASM Industries, Inc.

# VIII. GENERAL SAFETY INFORMATION FOR HANDLING FLAMMABLE AND COMBUSTIBLE LIQUIDS

## WARNING

When using a hand pump to fill cans, drums or other portable or fixed containers with flammable or combustible liquids such as gasoline, both container being pumped from and the container being pumped to must be effectively BONDED and GROUND to prevent discharge of sparks of static electricity which could cause explosion.

BONDING is the electrical interconnection between containers (such as a drum and a receiving can). Bonding must be completed BEFORE pumping begins. See diagrams.

GROUNDING is the electrical connection between a container and a "constant ground". A "constant ground" would be a metal pipe or rod in contact with the earth. An underground tank and piping connected to it would be inherently grounded by nature of the installation. See diagrams.

Both BONDING and GROUND of containers of flammable liquids are required under U.S. Gov't. OSHA regulations and National Fire Protection Association Code 77, Static Electricity.

Consult factory for specific liquid handling recommendations.

High quality BONDING and GROUNDING wires are available through the factory. Order part number P-58-1212 01.

